

# ELECTRICAL Designer the solution for electrical engineering, design, hydraulics & pneumatics

## Benefits

- Easy to learn & use, ensuring a rapid return on investment
- Increased productivity and supporting documentation quality
- Automatic generation of supporting documentation: BOM's, Parts lists, Connection reports...
- Reduced costs and design time by eliminating common design errors
- Extensive standards libraries, components and cabinets
- Connection to manufacturers' parts databases
- Multiple scheme libraries to DIN, IEC, NEN, BS, ANSI, JIC, etc. standards
- Automatically generate information in Word, Excel, Access, Lotus, HTML, PDF, Data Exchange Format, Text etc.

## Technical Specifications

Requirement for EDPRO / LT are the same as those for AutoCAD / AutoCADLT2002 to 2009, for Windows XP operating systems. *(Only 2009 is compatible with Windows Vista)*

**ED PRO** 100% compatible with AutoCAD 2002 to 2009, or AutoCAD Electrical / AutoCAD Mechanical / Mechanical Desktop.

**ED LT** 100% compatible with AutoCADLT 2002 to 2009.

**PRO LT** Data created in PRO and LT version is 100% compatible, in the same version. Both versions contain the same commands and performances

## Differences PRO / LT

The difference between EDPRO and EDLT are that they run on different AutoCAD platforms, the electrical functionality is the same for both.

Apart from the above there are certain options available in full AutoCAD that are not available for AutoCADLT, although they do not affect ED's performances.

1. it is possible to make use of programming languages such as Lisp, Visual Basic, etc.
2. there are tools for the edition of 3D solids and options to handle 3D data generally.
3. it has shading options for the generation of picture-realistic components

## Versions

Clients can operate on standalone systems or on a network, (LAN, etc) to share data

Two options are available, Industrial, Educational, each available in 6 modules

ED educational license includes five modules (1+2+3+4+5), and it is limited, in terms of data management exclusively, to 8 schematic drawings per project (generated reports, terminals drawings or cabinets layouts have no limits). The rest of functionalities are no limited

## Features / Modules

ELECTRICAL Designer allows you to combine only those modules that you require

## MODULE 1: SCHEMATICS

The core module provides users with a range of management and design tools to automate and speed the production of projects, scheme drawings, and all associated documentation in native AutoCAD Dwg and DXF formats. Includes library symbols standards, and manufacturers parts data as standard

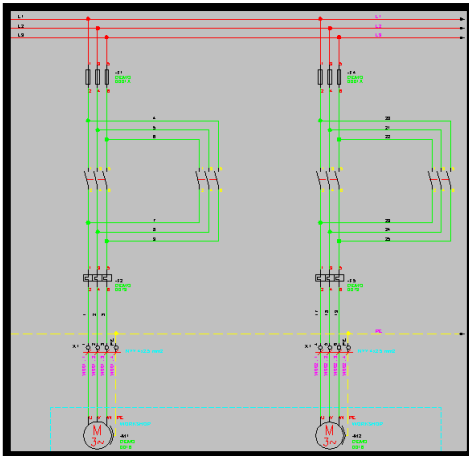

Main features:

- Project and drawing management system
- Multi level fast find facility.
- User access and network control.
- Automatic batch plotting / transmittal / collation / no. of copies
- On line language selection
- Multi lingual assisted technical translations
- Extended drawing tools for electrical drafting
- Automatic numbering of circuit elements with user-definable formula to standards like IEC, ANSI...
- Connection analysis with automatic location of nodes.

- Fully automatic cross-referencing on line and cross-reference error checking
- Navigation between scheme and cabinet components
- Estimation analysis of costs based on "man hours". Automatic generation of reports, BOM's, Parts lists...
- Reverse engineering. Create material lists prior to doing any scheme design, and then generate cabinets and/or scheme's from the report data.
- Manufacturers catalogue data.
- Automatically export information to labelling machines such as Critchley, Wago, Weidmuller, Partex etc
- Automatic generation of lists of projects, drawings, libraries, elements, catalogues, and references
- Save reports in Dwg format, Word, Excel, Access, Text, ODBC, HTML, Excel, DIF, etc. and have them available to you through the ED manager
- Possibility to communicate with more advanced PDM, MRP systems.
- Import, integrate, and use AE / AutoCAD drawings.
- Complementary Manager option to allow other departments to create reports, print drawings, etc without requiring AutoCAD

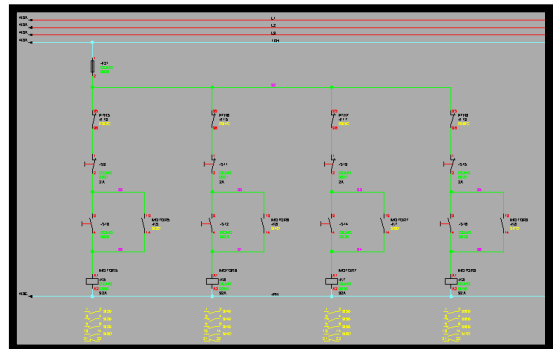

## MODULE 2: Assembly Module

The assembly module drastically reduces the time it takes to create cabinets. Assuring data consistency between scheme drawings and cabinet layouts. Changes made to scheme numbering will automatically be adopted by cabinet components. Components removed from a cabinet that exist in a scheme, or scheme elements removed from a cabinet are graphically displayed as being “orphaned”.

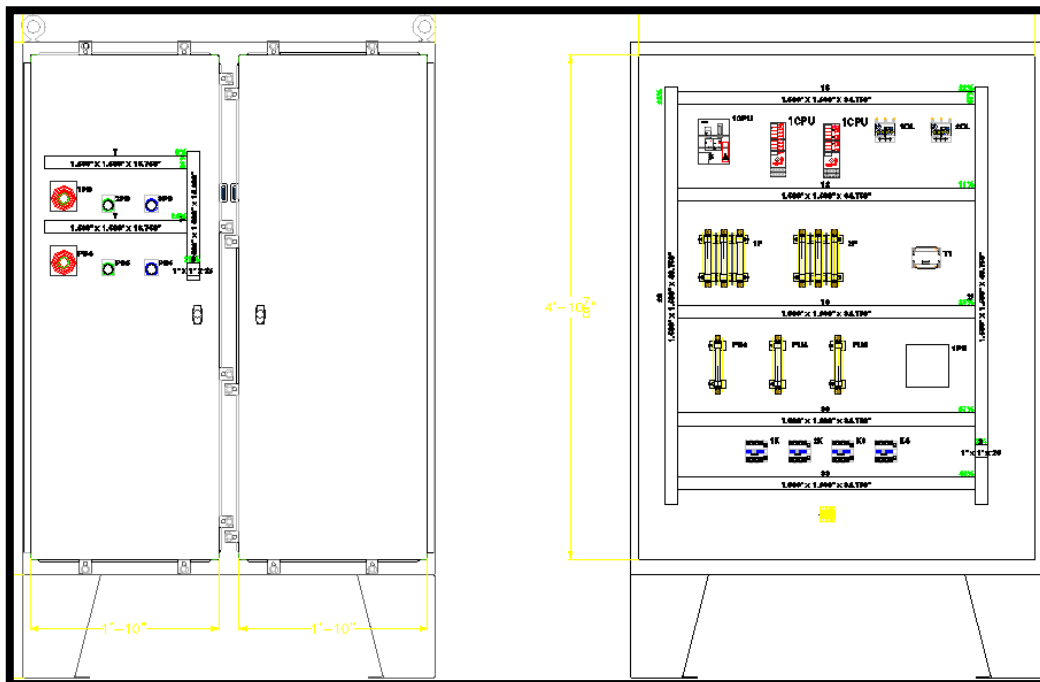

3D models are automatically created from manufacturers dimension data. Multiple components can be placed in the correct cabinet location at the same time, and the cabinet viewed in 3D to carryout quick and easy clash detection checks.

- Semi automatic creation of 3D assembly/layout drawings.
- 3D panel views. No need to learn 3D. Placement of components will be on the correct view and elevation.
- Multiple placement, with auto spacing of cabinet components
- Major manufacturers enclosure footprint drawings ( Hoffman, Himel, Sarel, Schneider electric, Eldon Electric, Rittal)
- Automatic dimensioning
- Automatic detection and reporting of inconsistencies between schematics and layout drawings
- Component surface area/volume analysis to determine cubicle size
- Library element slide drawings automatically created
- Batch process elements, print, rescale, clean...

## MODULE 3: CONNECTIONS and CABLES

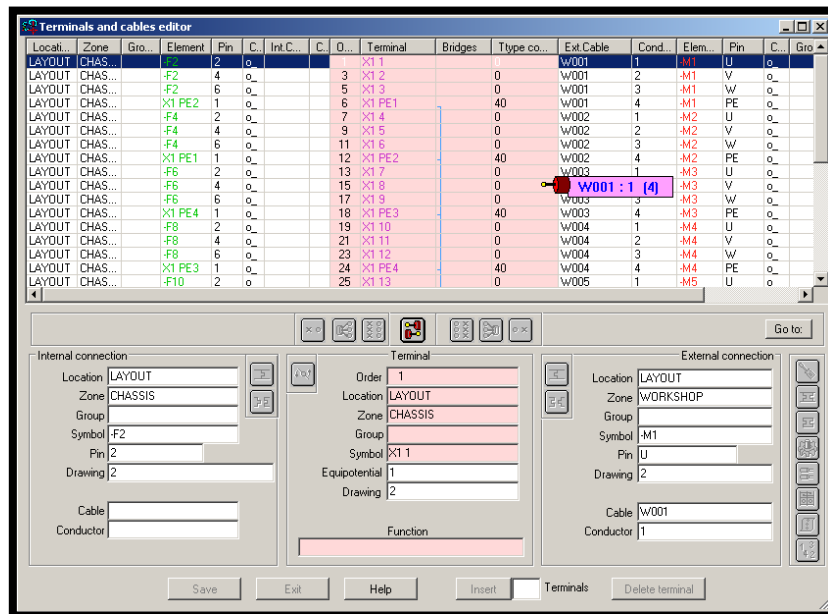

The Connection and Cables editor is an advanced management tool for the manipulation of terminals and devices. Assign cables to scheme terminals and elements, automatically generate terminal wiring diagrams, and define connections between terminals and/or elements. All data generated is fully consistent with the schematic data due to an intelligent bi-directional feed.

- Graphical interfaced terminal, cable and harness editor
- Automatic generation of terminal block drawings
- Automatic generation of terminal lollipop drawings
- Automatic creation of terminal and cables reports
- Inconsistency detection between connections and numbering
- Automatic generation of wire connection reports in addition to connection analysis
- Project batch processing. Used to update, renumber, reset etc. all drawings
- Cables manufacturer part data included in BOM's
- Multi deck terminals
- Terminals editor. Multi-selection of terminal strips to modify terminal drawing parameters.
- Possibility to assign 64 different graphical terminal types for inclusion in terminal drawings.

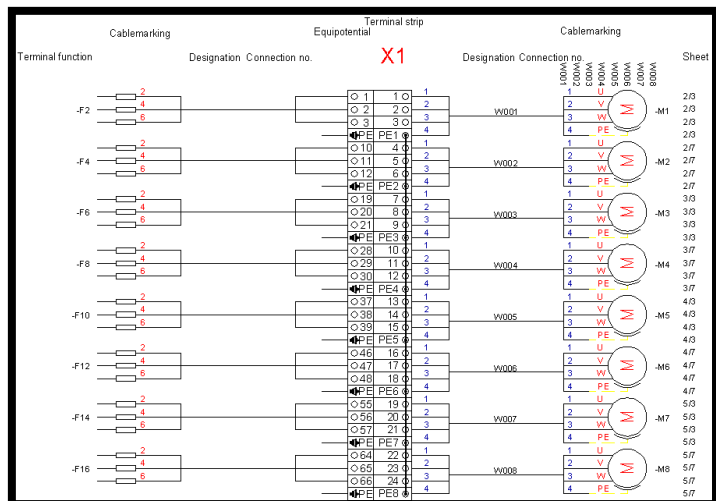

## MODULE 4: PLC

The PLC module ensures consistency of information between the PLC programming software and your schematics. Address, comments, labels etc. can be imported or exported to any manufacturer's PLC ladder software, (Mitsubishi, Omron, RS-Logic, etc).

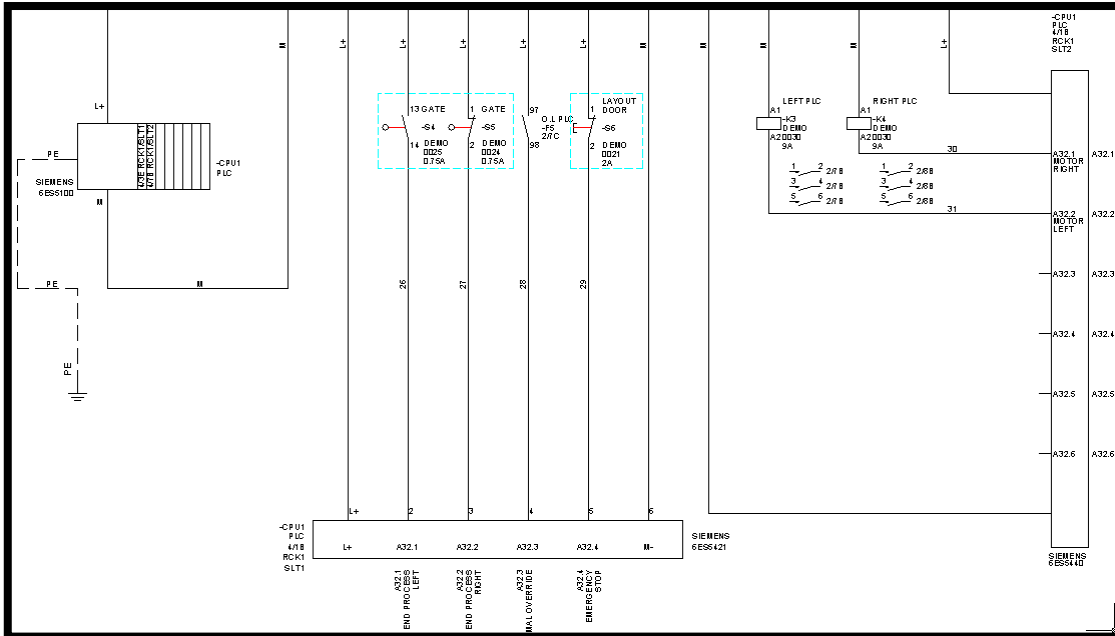

This means that the I/O information for the ladder software can be generated, error free, automatically from the schematics. The PLC module can also import the information from any manufacturer's PLC ladder software program and automatically write the I/O information, error free, to the schematics

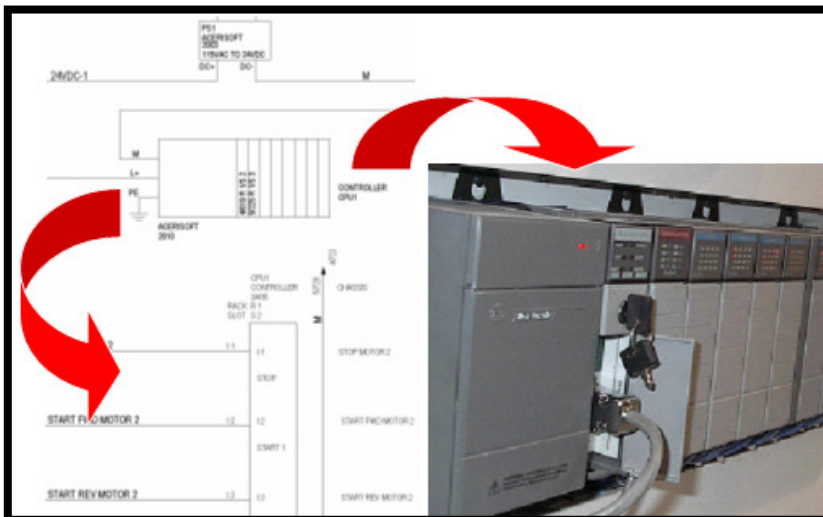

The PLC module can also export information to manufacturers programs to write information automatically to PLC on site to avoid potential errors.

In addition to this the PLC module incorporates the following features.

- Copy information from PLC's to wires, terminals, elements.
- Automatic numbering of pins, address, label using numeration systems such as hexadecimal, decimal, binary etc.
- Cross referencing between CPU's PLC Slots and PLC sub slots
- Import/assign comments, label, description, pins, address to PLC's
- Automatically generate I/O PLC reports
- Navigate between CPU's Slots and Sub slots.

## MODULE 5: MAX / 3D Cabinets

Eliminate the need for engineers to spend hours designing the cabinet wiring diagrams.

From to lists, ensure that the installation engineers can easily realise the cabling defined by the design engineers. The software will automatically determine the shortest possible route between two components to reduce design times and cut your costs. Elimination of errors, and reduced design times will greatly reduce design costs. This module considers the true cable type, and allows for segregation of cables, and will automatically report on trunking fill factors, packing density, number of wires per trunking route etc.

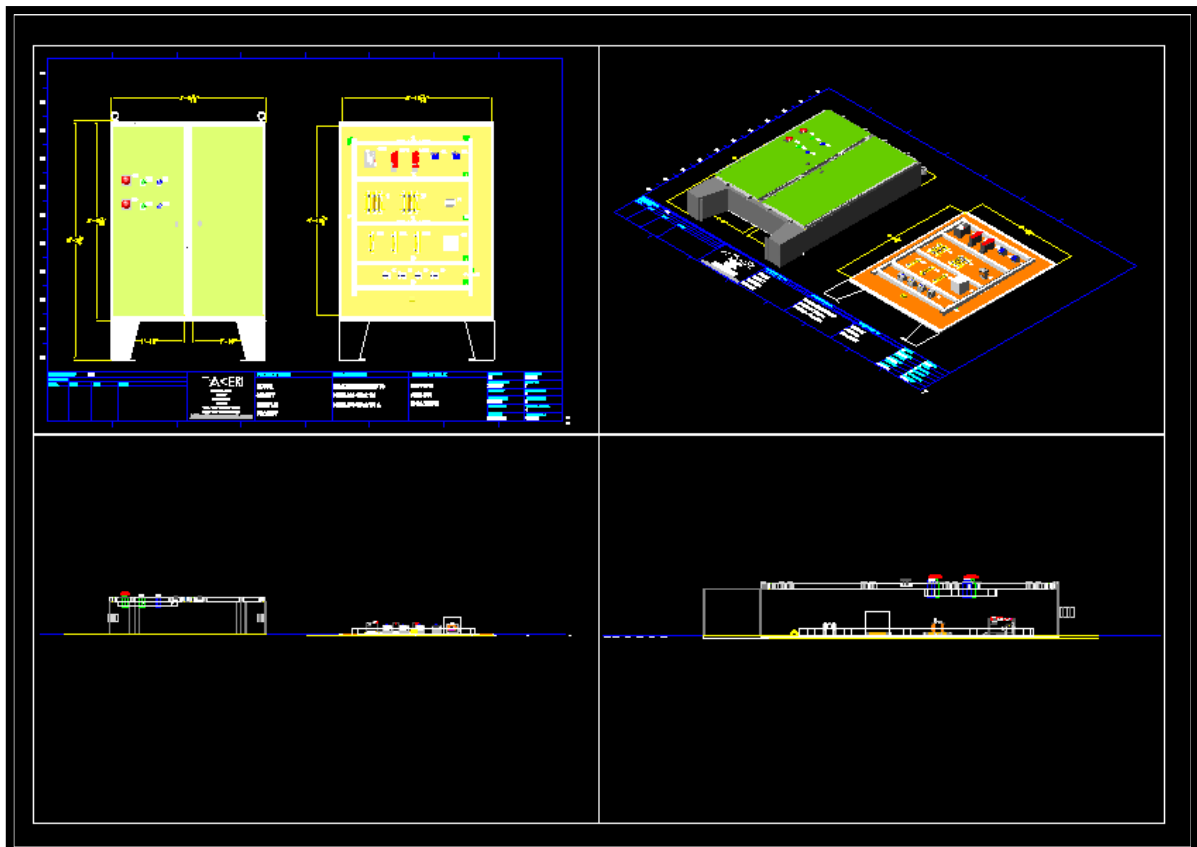

- Intelligent 3D trunking/raceways
- Export wire numbering, wire lengths, to wire labelling/cutting machines.
- Automatic true point to point cabling of components in the cabinet, based on the shortest possible route.
- Manual/automatic segregation of cables
- Open and closed circuit connections
- Specific cabinet component numbering
- Automatic calculation of trunking fill factors
- No need to learn 3D
- Support all numbering standards including KKS
- DIN Rails
- User configurable secondary numbering system for trunking routes to increase the quality of the reports
- Trunking specific reports
- From To lists specify true length, colour, gauge, trunking routes used to connect components...

## MODULE 6: SQL / Advanced Automation

This extension sees a complete reworking of the programs internal architecture, replacing the current databases with one SQL SERVER 2000 database.

Some of the benefits clients using this system can expect include:

- Vastly increased process speeds regardless of project size.
- Eased integration/connectivity to an increased range of programs including PLM, PDM, ERP...
- Greater range of reporting options, access any ED data to create any report types, from thousands of database fields.
- Increased data security, with "disaster recovery" systems"
- "Alien" database connection & integration into ED's SQL database... "

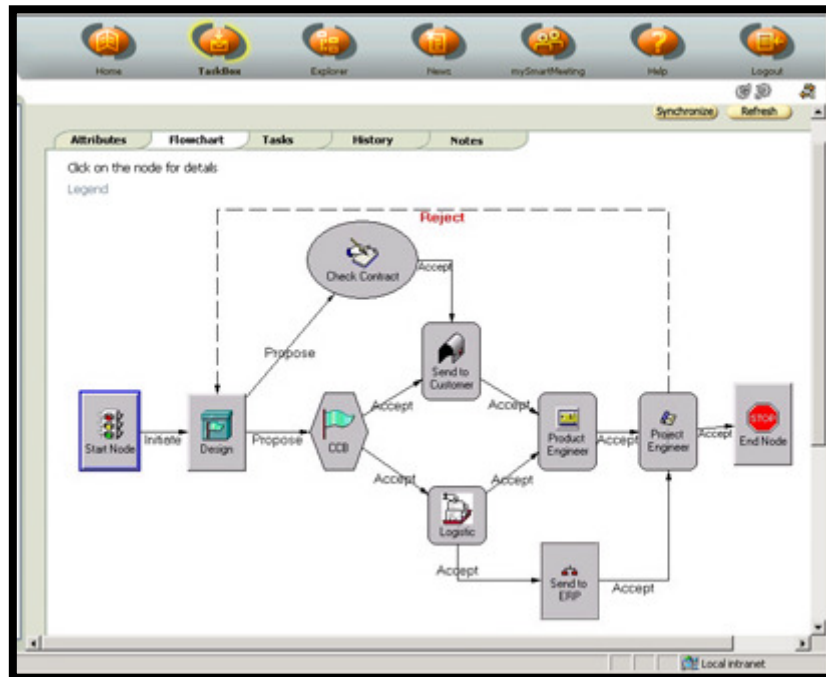

- Work on, and share ED data within a world-wide multi server environment.
- Directly write information to ED's SQL database and make "real-time" drawing amendments

All ED SQL data fully compatible with other ED versions and releases.

With the release of this new module, clients will be have the opportunity to share, modify, create and handle intelligent electrical project data in a fast, flexible, open environment, to produce higher quality data and supporting documentation than ever before.

**Technical requirements**

AutoCAD Electrical 2007, AutoCAD Electrical 2008 or AutoCAD Electrical 2009

**System Requirements**

Please refer to the Autodesk web site for the system specification:

**Versions**

Standalone or network (concurrent) licenses available.



**for further information or to request a demonstration:**

**ACERI**

Vendelier 61  
3905 PD Veenendaal  
Nederland

Benelux please email <a href="mailto:info@Aceri.nl">info@Aceri.nl</a>	or call	0031 (0) 318 616 924
All other countries <a href="mailto:sales@aceri.com">sales@aceri.com</a>	or call	0034 (0) 934 531 206